



OCS NEWSLETTER

Intake 9



INTAKE 9 ISSUE 5 / APRIL 2013

INSIDE THIS ISSUE



HANDGUN P226
Pg.2



CFT
Pg.2



HELI EMBUS/DEBUS DRILLS
Pg.3



PUBLIC ORDER
Pg.3

EDITORIAL TEAM

50240 OCDT (L) ALI OMAR BIN HAJI SULONG

50249 OCDT (L) ANIS BIN ABD RAZAK

50239 OCDT (L) BAHNUM BIN HAJI SUHALI

50248 OCDT (U) MUHD FAUZI BIN HAJI MOHD DAUD

50241 OCDT (L) MOHD AKHMAL BIN MOHD. AKBAL

21710 OCDT DK SITI AISHAH NORPEMAR BINTI PG. HAJI ABU BAKAR

21719 OCDT SITI NURATIKA SRI MU'IZZAH BINTI MOHAMMAD HADI MUSLIM



CO CHALLENGE

The CO's challenge is one of many requirements by OCS as to produce officers who are at highest quality and calibre. Officer Cadets, both male and female need to push themselves beyond the limits in order to show their capabilities to lead their subordinates. The CO's challenge has been designed and introduced since the first intake of OCS and is still on going in succession with following intakes and has become a tradition for sections in between each intake to achieve glory. The winners would have the privilege to have their names engraved on the trophy, which would be showcased in the OCS showroom.

This year's challenge painted a picture where each section have to work as one mobile unit in order to pass through several challenges such as carrying casualties to an evacuation point in which it mirrors the real situation if things went wrong or not according to plan. This requires basic military knowledge skills such as the principles of war and combat estimates. Furthermore, respective sections need to cross a river together with all their combat gear including rifle and back pack. Other than that, each section needs to complete an obstacle course which consists of climbing a 12 feet high wall and crawling to get through the next obstacle in order to give imagination when to evade and withdraw from enemies that are in pursuit. The last task proved to be even challenging where each section have to carry a log for about 2km. The real challenges at that time were exhaustion and tiredness. And as a leaders, they need to showcase their skills and capabilities to motivate and lift up their subordinate spirits to finish the task.

Combination of all the tasks are designed specially to train and assess the physical and mental strength of each officer cadets of intake 9 prior to holding specific roles and completing them within the time constraints. To be an officer, one must have both physical and mental strength. The main aim is however to evaluate whether the cadets are equipped with the composure and fitness as well as the ability to think critically in leading their subordinates during times of stress and at their weakest.

Teamwork is the key for success in facing obstacles. This is necessary as it would only equip the RBAF with capable and effective leaders to lead the organisation and aid them to spearhead its development and progression.



HAND GUN P226



Characteristics

Type: Double/Single Action or Double Action Only semi-automatic

Caliber: 9x19mm Luger, .357 SIG, .40SW

Length, overall: 196 mm

Barrel length: 112 mm

Weight (with empty magazine): aluminum frame: 870g (9mm), 920g (0.40 and 0.357)
stainless steel frame: 1180 g

Magazine Capacity: 15 rounds (9mm); 12 rounds (.40 and .357)

Intake 9 had undergone weapons handling training for P226 in order for them to be equipped with the necessary skills, and experience in order to counter any stoppages. It is a short range weapon with an effective range of 25 metre and is mainly used as a secondary weapon should our primary weapon run out of ammo. It became one of the most popular service pistols, being used by military, police, and security forces, as well as by civilians around the world.

Commissioned officers are issued this weapon as it is mobile and easy to carry around. It provides them with a safety net during times of distress and worse case scenarios as it is very easy to hide due to

Indirectly, it gave us a practice as future officer in the future, we would only be equipped with handguns to lead our men. Furthermore, officers should learn the different varieties of weapon handling to show the worthiness of being officer and a leader. In addition in the real situation during war, it can be use as a back up weapon if the primary weapon is out of use or running out of ammo.

Thus, learning handgun drills is essential as any type of weapons drill that have been learned.



CFT

The Combat Fitness Test (CFT) is an exercise where officer cadets are ordered to run long distance in one group within specified time. The key objectives of the CFT are to make sure that all officer cadets are able to run from the starting point to the end without leaving their squads behind.

Esprit de corps is very important in this exercise as well as speed in time management because the time given is always limited. The Officer cadets are anticipated to help each other so as to make the CFT a success, in accordance to the intake 9 motto says that 'We Prevail As One'. The CFT of intake 9 which consists of 38 officer cadets was held in the Royal Brunei Air Force (RBAirF) base with a distance of 12.8km within 2 hours in full combat attires.

Platoon commander and platoon sergeant are appointed to give a proper command and control in manoeuvring the group to the finishing line. It is their responsibilities include taking care and maintaining the group from being dispersed.

Within this, the most important point is to make sure that the officer cadets are capable in maintaining teamwork among themselves, fighting with mentality as well as the strength in their fitness. Being able to balance and manage the mentality, importance of teamwork, communication and the physical strength shows a good role model as a leader especially in RBAF.



HELI EMBUS/ DEBUS DRILLS



The purpose of learning Helicopter drill is for the safety and knowledge of the officer cadets. We were taught on how to enter and evacuate from three different types of helicopter used by RBAF carrying capacity play a huge role in its safety feature which are Bell 212, Bolkow and Blackhawk S78-33. The Bell 212 can fit a maximum of up to 15 passengers, the Bolkow can only fit up to 5 passengers and Blackhawk can carry more than the Bell212 which is up to 22 passengers. Exceeding the carrying capacity may reduce its functionality and cause the helicopter to run below par.

There are also four positions on how to evacuate from the helicopter when you cannot land on open areas, and two positions on how to evacuate from the helicopter when you are flying above sea. OCS intake 9 were given additional information on the need to wear life jacket. It is necessary to wear and get ready in case there is an emergency when flying above sea area. Moreover, it can secure you from being drowned if the helicopter crashed into water.



Public order is an Operation Other Than War (OOTW) which has become one of the RBAF's responsibilities to keep peace especially in regional states. The military main task is not only focusing jungle operation but in the urban area as well. As for the officer cadets had conducted an operation named Counter Insurgency (COIN). The operation involves civilian in terms of facing the aggressiveness of the people. It challenged the physical as well as the mentality of the armies in standing during the riot. The operation conducted between intake 9 being the armed forces and intake 10 as the civilians conducting the riot.

In conjunction with the operation, two practicals had been done using APC as the vehicle. As a result, intake 9 has been tested physically and mentally ready for more exercises and indeed this operation could save many innocent civilian lives. Other than that, the officer cadets being trained in managing the riot as we will become leader that gives command and control to our subordinates. It shows how to make tactics and learn how to control our aggressiveness.

Meanwhile as a role of the RBAF, it has become our responsibility to serve His Majesty and protect our country from threads, riots, suicide bombers etc. Whereas, as for the longterm effects, it becomes reasonable for the officer cadets to have practise of the public order in order for them to learn how to control their man and situation if it is happening. Overall, it prepares officer cadets to overcome situations and manage in handling emergency conditions.



PUBLIC ORDER

"If one advances confidently in the direction of their dreams, and endeavours to lead a life which they have imagined. They will meet with a success unexpected in common hours." - Henry David Thoreau

CELESTIAL NAVIGATION

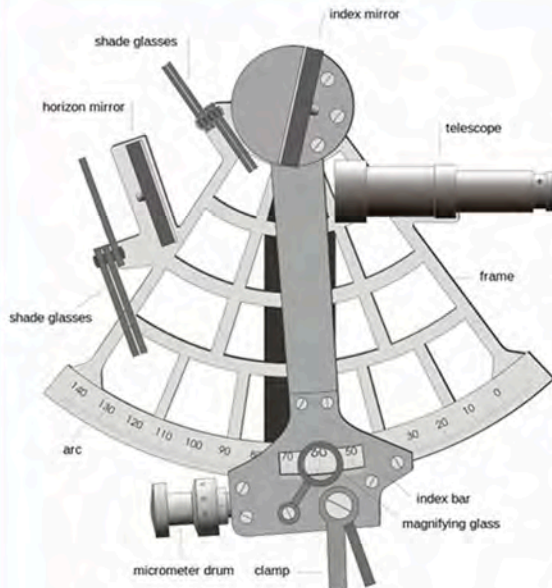

Celestial Navigation, also astronavigation, is a position fixing technique that has evolved over several thousand years to help sailors cross oceans without having to rely on estimated calculations, or dead reckoning to know their position. Celestial navigation uses "sights," or angular measurements taken between a celestial body (the sun, the moon, a planet or a star) and the visible horizon. The sun is most commonly used, but navigators can also use the moon, a planet or one of 57 navigational stars whose coordinates are tabulated in the Nautical Almanac and Air Almanacs.

It can use for the Royal Brunei Navy to navigate on the sea other than common navigation instrument. In order to compete with other countries in terms of defuse development and technologies.

Last but not least, by having the celestial navigator in the RBAF especially for the navy, it give option rather than depending on one instrument only.

Name: 50252 OCdt (L) Mohd Hamizan bin Haji Zaidin
D.O.B: 22 September 1988
Highest qualification: B.A Hons (Public Policy & Adiministration) University Of Brunei Darussalam

Bio:
It is an honour for me to be in the Officer cadet School as an Officer Cadet, and it is also a dream for every parents that their children to serve for the country as a soldier. why I choose to be in the RBAF is because to help my family and for its job security, i.e. pension. I promise to give all I can in order to pass through the sovereign parade with flying colours, my motto is "do work with full commitments, focus and quick". I believe if I can maintain this concept throughout 10 months training, later in the future I can get through any problem.



Name: 21713 OCdt Siti Husnul Katimah bt Hj Mohd Yassin
D.O.B: 29th April 1989
Highest qualification: B.A Degree Syariah University Of Jordan

Bio:
Throughout the course so far, I had never imagined that I could achieve to the level I am now. Having the right attitude is essential in order to go through this course. When feeling physically exhausted, mentality is challenged, especially in leadership assessment. We were taught to think and read when we are under pressure physically and mentally, this is when we put our mind over body. Being in the military have brought out the things. The course has thought me to do the very best I could in everything you do. You only like once, opportunity might only come once, so grip it like you will never have the chance again.



Name: 50236 OCdt (L) Mohd Samsul bin Awang Rosman
D.O.B: 04th September 1987
Highest qualification: Degree in B.Sc. Education University Of Brunei Darussalam

Bio: The training in the Officer Cadet School has changed my personality in different ways. This is the place where I learn a lot of things such as the concept of leadership and the spirit of teamwork. Other than that it thought me to be more disciplined and confident in any situation. Throughout the 6 months of training, we did a lot of tasks that required strong mental and spiritual strength. This help to prepare ourself to be at excellent standards set for officers. I wish to be one of the best navy officer for RBAF and prove to the outside world that OCS of Brunei Darussalam could be one of the best military institutes which produce the best leaders in the future.



MEET THE CADET